

New

M800 - Series

New M800 - series Overedger and Safety stitch machine



The new M800 development offers higher speed of up to **7000** rpm and ensures higher productivity. M800 - series offers many new features in comparison to M700. We introduce to you the **outstanding new technical points:**

- Fully enclosed needle bar casing, like MX and EX- series and the vacuum suction of the oil ensure
 - reduced noise from needle bar at high speeds
 - no excessive oil in the needle bar area

NEW

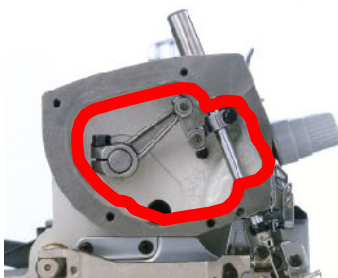

- An additional adjustment to the sewing condition is possible with
 - the high position
 - or down positionof the presser bar hinge mechanism

NEW

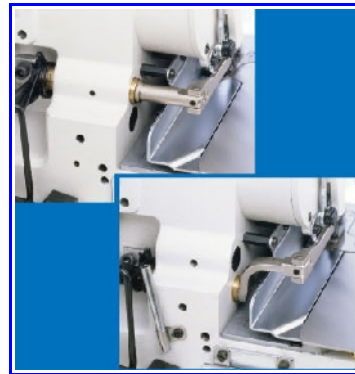

High axis is used for knitted fabric and Jeans machine. Low axis is used for woven fabric to reduce puckering.

- Improved ease of operation & maintenance
 - manually adjustable presser foot pressure
 - differential ratio adjustable from outside
 - movable needle guards
 - colour marked thread guides for easy and simple threading
 - tilt adjustment of feed dog bars from the outside

- Improved oil gaskets on oil pan and top cover, with “M” shaped O-ring

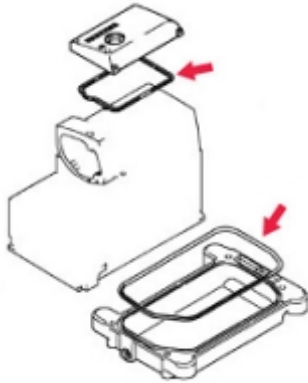

- Rustproof coated gauge parts to protect against fabric with chemical treatments and moisture
NEW

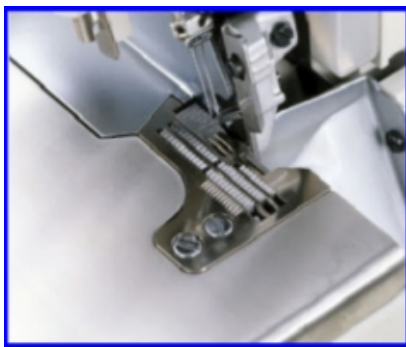

- 3 oil seals are used on the feed dog bars

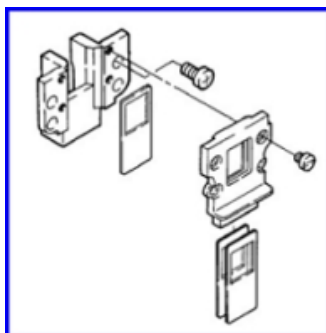

NEW

- Gauge parts from M700 are used for M800

Exception: **NEW**

The upper looper for 2-ndl (the models which have 2-ndl. overedger stitch, including -355) is newly designed.

The upper looper of M700 can not be used for M800 models which have 2-ndl. overedger stitch, including -355. All loopers from other subclass models are common with M700.

- New designed belt cover with closed rear side for improved safety
NEW

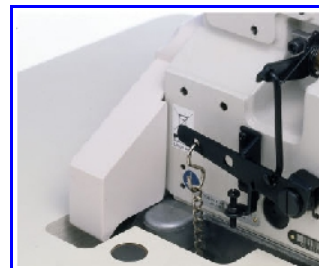

- Eye guard with closed left side for higher operator safety

NEW

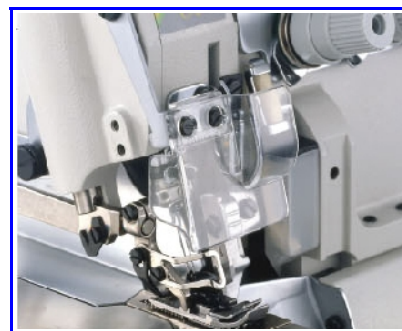

- **Common with M700:**
 - HR-device, for needle thread
 - and needle cooler

 - Movable needle guards

 - oil circulation check-up window on top cover and oil level window on front side of casting

➤ **Labour saving devices**

- Vertical chain cutter KS for the overlock machines, KS0C, KS0E
- Horizontal chain cutter KH for the safety stitch machines, KH0A, KH0B, KH0C
- Tape and chain cutter TK
 - a, solenoid driven
 - b, pneumatic driven
- New LC with lint collector

M800 - Common Specifications

Subclasses: **M852:** -01, -17, -16S2, -13 and -23B, (in plan -90) -13/Y with chaining land -180/BT0B, -181/BT0C
M832: -38, -70, -86, -355 -48, -48P2

Max. speed: 7.000 rpm * The maximum speed is different depending on the subclass and the sewing condition

Standard needle: B27

Presser foot: Tractor presser foot for -86, Jeans

Feed type: Differential bottom feed

Stitch length: 0.8 ~ 3,2 mm

Differential ratio: 1 : 0.7 ~ 1 : 2,8

Standard stitch length: max. 3,2 mm

Stitch length adjustment: Push button type

Diff. feed amount adjustment: Intermittent type (without micro adjust)

Devices : KH / KS, TK, LC

Available Subclasses:

1, M852 Overlock Machines

Plain seaming, 1- and 2-needles
 M852-01-4
 M852-17-4
 M852-16S2-1,5
 M852-13-2x4
 M852-23B-2,5x4,5
 M852-13-2x4/Y3061, with chaining land
 M852-90-6 (in plan)
 Manual BT, 1- and 2-needle
 M852-180-4/BT0B
 M852-181-2x4/BT0C

2, M832 Safety stitch machines

M832-38-3x4
 M832-70-5x5
 M832-86-5x6
 M832-355-3x2x4
 M832-48-3x4
 M832-48P2-3x4

3, M822 Double chain stitch machines

M822-02x250

PEGASUS EUROPA GMBH